

# SHIM JUN POOME-SAE FIRST DEGREE BLACK BELT

*Translates as "Begin Planting Seeds for the Future."  
Interpretation is new role of loyalty through physical and mental training*

**NEW BLOCKS:** "9" block. [16, 33]  
 Square block (open/closed). [34, 54]  
 Double blocks (open/closed). [34, 54, 55, 74]  
 Advanced double blocks. [1, 17, 76, 79]  
 Advanced double knifehand block. [6, 22]

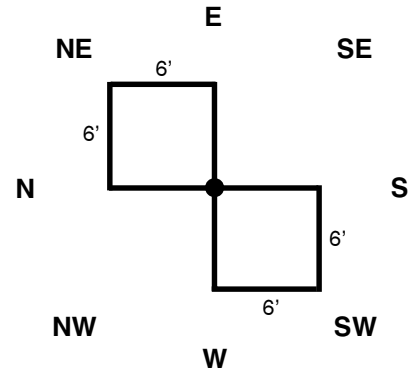

**NEW KICKS:** Foot stomp. [8, 24]  
 #1 jump hook kick. [15, 32]  
 Step forward spin hook kick. [47, 67]  
 Step forward #2 jump side kick. [75]

**TYPES OF MOVEMENT:** Tension movement (5 seconds in duration). [13, 30, 45, 65]  
 Slow movement (2 seconds in duration). [51, 71]  
 Circular movement. [7, 23, 78, 81]  
 Single arm blocks and strikes.

*Form should take about 2:05 to 2:10 minutes from attention to final bow  
 All advanced open hand techniques begin in a closed hand position (fist)*

**READY STANCE:** Left half command stance (Left fist high, right at side, parallel stance).

☆ June Bee - Half command stance.

- |   |   |  |
|---|---|--|
| 5 | [ | <ol style="list-style-type: none"> <li>1. Left foot steps northeast to middle stance (right heel pivots first, stance is with right heel and left toe on east-west line); left advanced double inner forearm block.</li> <li>2. No step, right upset punch to face level.</li> <li>3. No step, left palm middle upset block.</li> <li>4. No step, right middle punch.</li> <li>5. No step, left double hand middle punch.</li> </ol> |
| 2 | [ | <ol style="list-style-type: none"> <li>6. Left foot shifts to right back stance to east, advanced double knifehand block.</li> <li>7. No step, circle double knifehand low block.</li> </ol>   |
| 6 | [ | <ol style="list-style-type: none"> <li>8. Right foot steps forward in stomping motion to middle stance facing north, eyes to east.</li> <li>9. No step, right backfist to east high section.</li> <li>10. Left foot steps to right foot to closed stance, right side kick middle or high section to east (as #3 side kick).</li> </ol>   |

--- (Direction Change on Line Corner)---

## SHIM JUN POOME-SAE FIRST DEGREE BLACK BELT

- 6 [ 11. Right foot lands to left foot in low closed stance facing north (right foot on east point).  
Right high/low block with fists.  
12. No step, left high/low block with fists.  
13. Right foot steps north to left rear stance, right single knifehand low block with tension.
- 3 [ 14. #1 right front kick. Land in middle stance facing west, eyes to north.  
15. Left foot moves to right in closed stance. Right jump hook to north (as #1 jump hook kick).  
16. Land in right sparring stance to north (right foot on northeast point), right side "9" block to north.
- (Direction Change on Line Corner)---
- 5 [ 17. Double step northwest to middle stance with right toe and left heel on east-west line, right advanced double inner forearm block.  
18. No step, left upset punch to face.  
19. No step, right palm middle upset block.  
20. No step, left middle punch.  
21. No step, right double hand middle punch. Kihap.
- 2 [ 22. Right foot shifts to left back stance to west, advanced double knifehand block.  
23. No step, circle low double knifehand block.
- 7 [ 24. Left foot steps west in stomping motion to middle stance facing north.  
25. No step, left backfist to west high section.  
26. Right foot steps to left foot in closed stance, left side kick to west (as #3 side kick).  
27. Left foot lands to right foot in low closed stance (left foot on west point), left low X-block with fists facing north (left fist on top).  
28. Same stance, twin palm head grab to north.  
29. Right knee strike. Step down to left foot.
- (Direction Change on Line Corner)---
30. Turn counterclockwise to right rear stance (right foot on west point), left knifehand low block with tension to south.
- 3 [ 31. #1 left front kick. Land in middle stance facing west, eyes to south.  
32. Right foot moves to left in closed stance. Left jump hook kick to south (as #1 jump hook kick).  
33. Land in left sparring stance (left foot at center point), left side "9" block to south.
- 3 [ 34. Right foot steps south to left back stance to south, eyes to south square block with left fist and right knifehand.

## SHIM JUN POOME-SAE FIRST DEGREE BLACK BELT

- 3 [ 35. No step, eyes to east, right middle upset knifehand strike to east. Keep fist in high block.  
36. Right foot shifts to right front stance, left reverse vertical middle punch to south.
- 5 [ 37. #3 Right jump front kick.  
38. Land in right front stance, high reverse palm heel strike to south.  
39. Right foot pulls to left in low closed stance with body facing east, eyes to south. Right inward inner forearm low block to south.  
40. Left foot moves counterclockwise to middle stance facing west (left foot on south point), eyes to south left horizontal elbow strike to south high section.  
41. No step, left high knifehand strike to south. Kihap.
- 5 [ 42. Right foot steps to left foot to low closed stance facing south (both feet on south point). Knifehand high X-block to south (right hand is on top).  
43. No step, left high knifehand strike to south.  
44. Left knee strike to south. Knee strikes left palm. Step down to right foot.
- 5 --- (Direction Change on Line Corner)---
- 4 [ 45. Right foot steps west to left rear stance to west (left foot on south point); right high ridgeland block with tension (left fist at left side during block).  
46. No step, right high spearhand strike to west, slow.
- 4 [ 47. Left foot steps forward one (1) rear stance length, right spin hook kick to west.  
48. Land in middle stance facing north (right foot at south point), eyes to west, left low block to west.  
49. No step, left high inner forearm block to west.  
50. No step, left middle punch to west.
- 4 [ 51. Right foot steps to left foot in closed stance, left slow side kick knee level to west (as #3 side kick). And...  
52. In a continuous motion left round kick to middle section. And...  
53. In a continuous motion, left round kick to high section (or middle section).  
54. Land in left sparring stance to west (left foot on west point), left double low block with left knifehand and right fist.
- 3 [ 55. Double step, turning 270 degree counterclockwise to right back stance to north (right foot on west point), eyes to north, square block with left knifehand and right fist.  
56. No step, eyes to east, left middle upset knifehand strike to east, keep fist in high block.  
57. Left foot shifts to left front stance to north, reverse vertical middle punch to north.

## SHIM JUN POOME-SAE FIRST DEGREE BLACK BELT

- 5 [ 58. #3 left jump front kick to north.  
59. Land in left front stance, right high reverse palm heel strike to north.  
60. Left foot pulls to right in low closed stance with body facing east, eyes to north. Left inward inner forearm low block to north.  
61. Right foot moves clockwise to middle stance facing west (right foot on northwest point), eyes to north, right horizontal elbow strike to north high section. Kihap.  
62. No step, right high knifehand strike to north.
- 4 [ 63. Left foot pulls to right, pivot counterclockwise to low closed stance to south (right foot at northwest point), left high low knifehand block to south.  
64. No step, right high/low knifehand block to south.
- 4 --- (Direction Change on Line Corner)---
- 4 [ 65. Left foot steps east to right rear stance, left high ridgehand block with tension (right fist is at right side during block).  
66. No step, left high spearhand strike to east, slow.
- 4 [ 67. Right foot steps forward one (1) rear stance length, left spin hook kick to east.  
68. Land in middle stance facing north (left foot on west point), eyes to east, right low block to east.  
69. No step, right high inner forearm block to east.  
70. No step, right middle punch to east.
- 4 [ 71. Left foot steps to right foot in closed stance, right slow side kick knee level to east (as #3 side kick). And...  
72. In a continuous motion, right round kick to middle section. And...  
73. In a continuous motion, right round kick to high section (or middle section).  
74. Land in right sparring stance to east (right foot on center point), double low block to east with right knifehand and left fist.
- 4 [ 75. Left foot steps forward one (1) sparring stance length, #2 right jump side kick to east.  
76. Land in left back stance, left foot in place, advanced double outer forearm block to east.  
77. No step, left middle reverse punch to east.  
78. No step, circle low double outer forearm block to east.
- 3 [ 79. Right foot steps back 180 degrees counterclockwise to right back stance (right foot on center point), advanced double outer forearm block to east.  
80. No step, right middle reverse punch to east.  
81. No step, circle low double outer forearm block to east.

Bah-ro - Left foot steps back to ready position.

Shi-uh - At ease position.

Copyright 1984 & 1997, American Taekwondo Association. (October 15, 1997)

AMERICAN TAEKWONDO ASSOCIATION HEADQUARTERS  
6210 Baseline Road, Little Rock, Arkansas 72209 / 501-568-2821

## SHIM JUN

☆ June Bee - Half Command Ready Position

		STANCE	SECTION			STANCE	SECTION
	1. L Double Inner Forearm Block	M	H		42. B Knifehand X-Block	C	H
	2. R Upset Punch	M	H		43. L Knifehand Strike	C	H
5	3. L Palm Upset Block	M	H	5	44. L Knee Strike	C	M
	4. R Punch	M	M		45. R Ridgehand Block	R	H
	5. L Punch	M	M		46. R Horizontal Spearhand	R	H
2	6. L Adv Double Knifehand Block	B	H		47. R Step Spin Hook Kick	--	M/H
	7. L Circular Dbl Knifehand Low Block	B	L		48. L Low Block	M	L
	8. R Stomp Kick	M	L	4	49. L Circular Inner Forearm Block	M	H
	9. R Back Fist	M	H		50. L Punch	M	M
6	10. R #3 Side Kick	--	M/H		51. L #3 Side Kick	--	L
	11. R High/Low Block	C	H&L	4	52. L Round Kick	--	M
	12. L High/Low Block	C	H&L		53. L Round Kick	--	M/H
	13. R Knifehand Low Block	R	L		54. L Double Low Block (L-Knifehand, R-Fist)	S	L
3	14. R #1 Front Kick	--	M/H		55. L Square Block (R-Fist, L-Knifehand)	B	H
	15. R #1 Jump Hook Kick	--	M/H	3	56. L Upset Knifehand Strike	B	H
	16. R Nine Block	S	M&L		57. R Reverse Vertical Punch	F	M
	17. R Double Inner Forearm Block	M	H		58. L #3 Jump Front Kick	--	M/H
	18. L Upset Punch	M	H		59. R Reverse Palm Strike	F	H
5	19. R Palm Upset Block	M	H	5	60. L Inward Inner Forearm Block	C	L
	20. L Punch	M	M		61. R Horizontal Back Elbow Strike - Ki-hap	M	H
	21. R Punch - Ki-hap	M	M		62. R Knifehand Strike	M	H
2	22. R Advanced Dbl Knifehand Block	B	H		63. L Knifehand High/Low Block	C	H&L
	23. R Circular Dbl Knifehand Low Block	B	L		64. R Knifehand High/Low Block	C	H&L
	24. L Stomp Kick	M	L	4	65. L Ridgehand Block	R	H
	25. L Back Fist	M	H		66. L Horizontal Spearhand	R	H
	26. L #3 Side Kick	--	M/H		67. L Step Spin Hook Kick	--	M/H
7	27. L X-Block	C	L		68. R Low Block	M	L
	28. B Head Grab	C	H	4	69. R Inner Forearm Block	M	H
	29. L Knee Strike	--	M		70. R Punch	M	M
	30. L Knifehand Low Block	R	L		71. R #3 Side Kick	--	L
	31. L #1 Front Kick	--	M/H	4	72. R Round Kick	--	M
3	32. L #1 Jump Hook Kick	--	M/H		73. R Round Kick	--	M/H
	33. L Nine Block	S	M&L		74. R Dbl Low Block (L-Fist, R-Knifehand)	S	L
	34. R Square Block (L-Fist, R-Knifehand)	B	H		75. R #2 Jump Side Kick	--	M/H
3	35. R Upset Knifehand Strike	B	H		76. R Adv. Dbl Outer Forearm Block	B	H
	36. L Reverse Vertical Punch	F	M	4	77. L Reverse Punch	B	M
	37. R #3 Jump Front Kick	--	M/H		78. R Circular Dbl Outer Forearm Low Block	B	L
	38. L Reverse Palm Strike	F	H		79. L Adv. Dbl Outer Forearm Block	M	M
5	39. R Inward Inner Forearm Block	C	L	3	80. R Reverse Punch	B	M
	40. L Horizontal Back Elbow Strike	M	H		81. L Circular Dbl Outer Forearm Low Block	B	L
	41. L Knifehand Strike - Ki-hap	M	H				